

Checkweighing Systems

9477 / 9477 MACH II

WEIGHING CONVEYOR

The METTLER TOLEDO model **9477** weigh conveyor is built for industrial applications using C-channel framing along with 2" square tubing for strength and durability. The upper deck is built with a flat steel plate for smooth weighing between the two balanced steel rollers. The weighing mechanics uses four 250 lbs load cells located in the corners to detect weights no matter where the package is tracking along the weigh bed. The system also uses a dual photo eye configuration to detect cartons as they enter and exit the weigh bed, this allows us to get the most allowable weigh time for each carton no matter the length. The dual photo eyes also allows the unit to detect if a carton enters the scale before the previous carton has exited so no bad weights are averaged into the final output.

The METTLER TOLEDO model **9477 MACH II** weigh conveyor is built to run at speeds from 250 FPM (feet per minute) to 600 FPM. The primary difference from the standard machine is that all the framing and rollers above the load cells are made of aluminum, which decreases the top load weight and increases the readability of the load cells. The aluminum rollers are spin balanced to a much tighter spec, and a seamless woven belt is added to reduce vibration.



9477

Applications

- OEM machinery
- Check weighing
- Shipping and receiving

Standard Features

- Standard belt size: 24" x 47"
- 32" +/- 2" conveyor height
- Four (4) load cells
- Dual photo eyes
- Fixed belt speed (30-240 ft/min.)
- Black PVC, coated belt construction
- 2 Sets of documentation with each order

Options

- Custom length/weight/height conveyors
- Variable belt speed
- USDA/Food construction (304 stainless steel frame/ FDA Approved white PVC belt)
- CSA Construction
- Hazardous Area construction
- MACH II Construction (speeds up to 600 ft/min.)

Specifications

Environmental protection:

Black, polyurethane painted mild steel construction or stainless steel

Hazardous protection:

9477: Class I or II, Division I or II, groups C, D, E, F, and G (optional)

Custom sizes:

9477: 12" through 42" W/ 24", 36", 47" (B) through 84" L/ 24" through 56" H (A) (± 2" adjustable)

9477 Mach II: 24" through 42" W/ 47" through 84" L/ 24" through 56" H

Capability:

9477: 15 to 100 cartons per minute

9477 Mach II: 45 to 160 cartons per minute

Speed:

9477: Fixed – 30 through 240 feet per minute/ Variable - 30 to 100, 80 to 160, 120 to 200, 150 to 240 feet per minute

9477 Mach II: Variable from 250 through 600 feet per minute

Load cells:

Four (4) 5,000 division, 250 lb analog load cells

Photoeyes:

9477 & 9477 Mach II: Two (2) UL & CSA approved standard reflective for packages over 2" high, or an optional banner send receive for packages down to ¼" high

Motor:

9477: ¼ Horse power for scales smaller than 24 W x 47 L, ½ horse power for scales 24 W x 47 L and larger – 56C-face, TENV, 220/440V 3 phase

9477 Mach II: 1 Horse power (all sizes) – 56C-face, 220V, 3 phase

Belts:

9477: Seamless Habiset black or USDA approved seamless white

9477 Mach II: Woven belt (no seam)

9477 Mach II special features:

Anodized aluminum deck and mid-frame

Highly balanced aluminum rollers

Dimensions (in inches)

	9477 (Std.)	9477 MACH II (Min.)
A	32"	24"
B	47"	47"
C	24"	24"

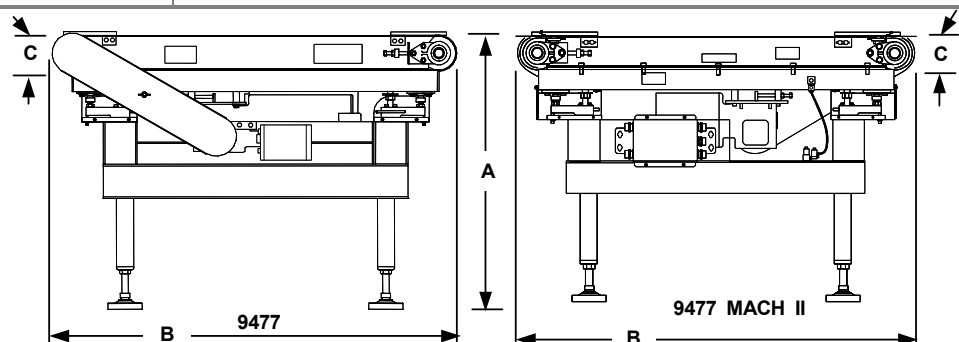

9477 Conveyor Model Number Configuration

	Size	Height	Finish	Belt Speed	Motor Voltage
9477 Configuration	XX	X	X	X	X

*Includes: Belt conveyor, load cells, analog junction box, and dual photo eyes.

	Configuration	Description	Lead-Time Standard 4 wks
Standard Size	GD	47" long x 24" wide x 32" height	4 wks
Special	GT	60" long x 24" wide x 32" height	+4 wks
	1A	24" long x 12" wide x 32" height	+4 wks
Custom Width and Length	See Note 3	Up to 42" total width	+6 wks
		Up to 84" total length	
Height	A	24" ± 2"	+1 wk
	B	26" ± 2"	+1 wk
	C	28" ± 2"	+1 wk
	D	30" ± 2"	+1 wk
	E	32" ± 2"	0
	F	34" ± 2"	+3 wks
	G	36" ± 2"	+3 wks
	H	38" ± 2"	+3 wks
	J	40" ± 2"	+3 wks
	K	42" ± 2"	+3 wks
	L	44" ± 2"	+3 wks
	M	46" ± 2"	+3 wks
	N	48" ± 2"	+3 wks
	P	50" ± 2"	+3 wks
	R	52" ± 2"	+3 wks
	S	54" ± 2"	+3 wks
T	56" ± 2"	+3 wks	
Finish	A	Mild steel black	0
	1	Stainless steel (USDA)	+6 wks

	Configuration	Description	Lead-Time Standard 4 wks
Belt Speed (Fixed)	A	30 FPM	0
	B	35 FPM	0
	C	40 FPM	0
	D	45 FPM	0
	E	50 FPM	0
	F	60 FPM	0
	G	70 FPM	0
	H	80 FPM	0
	J	90 FPM	0
	K	100 FPM	0
	L	120 FPM	0
	M	140 FPM	0
	N	150 FPM	0
	P	160 FPM	0
	R	180 FPM	0
	OR	U	240 FPM
K		30 to 100 FPM	+2 wks
Belt Speed (AC Variable)	P	80 to 160 FPM	+2 wks
	S	120 to 200 FPM	+2 wks
	U	150 to 240 FPM	+2 wks
Motor Voltage (Fixed Speed)	A	220 VAC/60 Hz	0
	B	440 VAC/60 Hz	0
OR	C	575 VAC/60 Hz	0
Motor Voltage (Variable Speed)	D	220 VAC/60 Hz	0
	E	440 VAC/60 Hz	0

9477 MACH II Conveyor

Description	Lead-Time Adder ¹
24" x 47" to 42" x 84", 240 to 600 FPM	6 wks

Options

Order Number	Description	Lead Time Adder ¹
KA274538GD000	47" x 24" (black)	0
KA274538GT000	60" x 24" (black)	0
KA2767321A000	24" x 12" (black)	0
KA275344GD000	47" x 24" (white)	0
KA275344GT000	60" x 24" (white)	0
KA2767331A000	24" x 12" (white)	0
Hazardous Area	Explosion-proof motors and photo eyes Hazardous Areas	+6/8 wks
CSA Construction	For units destined for Canada	+3 wks
KA277628 ²	Spare parts kit	

Notes:

- To determine actual lead-time add the standard 4 weeks to the lead time adder.
- For full spare parts kit number, add configuration number, same as conveyor.
- For a custom length or width scale contact factory. The length of a custom scale must be 1-1/2 times longer than the width.



Checkweighing Systems

Notes

